

**Powerful maintenance-free  
3-phase AC drive motor**

**Manoeuvrable and compact  
through short truck length**

**ProTracLink for maximum stability**

**Fully manoeuvrable with tiller in upright  
position using crawl speed button**



## **EJD K18**

### **Electric pedestrian pallet truck/stacker (2000 kg)**

The Jungheinrich electric pedestrian pallet truck/stacker EJD K18 can be utilised in two ways – as a horizontal mover, the EJD K18 is a cost-effective pallet truck over short transport distances; as a stacker, the EJD K18 picks up two Euro pallet stacked on top of each other at the same time and thus cuts travel times in half.

The short truck length of only 650 mm makes the truck compact, manoeuvrable

and suitable for many applications (e.g. in shops or very narrow warehouse areas). The additional benefit of a low overall height ensures that even smaller operators have a clear view of the fork tips.

The powerful 3-phase AC drive motor provides high productivity in any application, powerful acceleration and high top speeds. Battery capacities up to 250 Ah provide energy for long operating times.

The low mounted long tiller ensures that the operator is in full control of the truck's performance capacity at any time – even in the most confined spaces. Here, the crawl speed button with automatic crawl speed limit facilitates safe manoeuvring with the tiller in an upright position.

# EJD K18

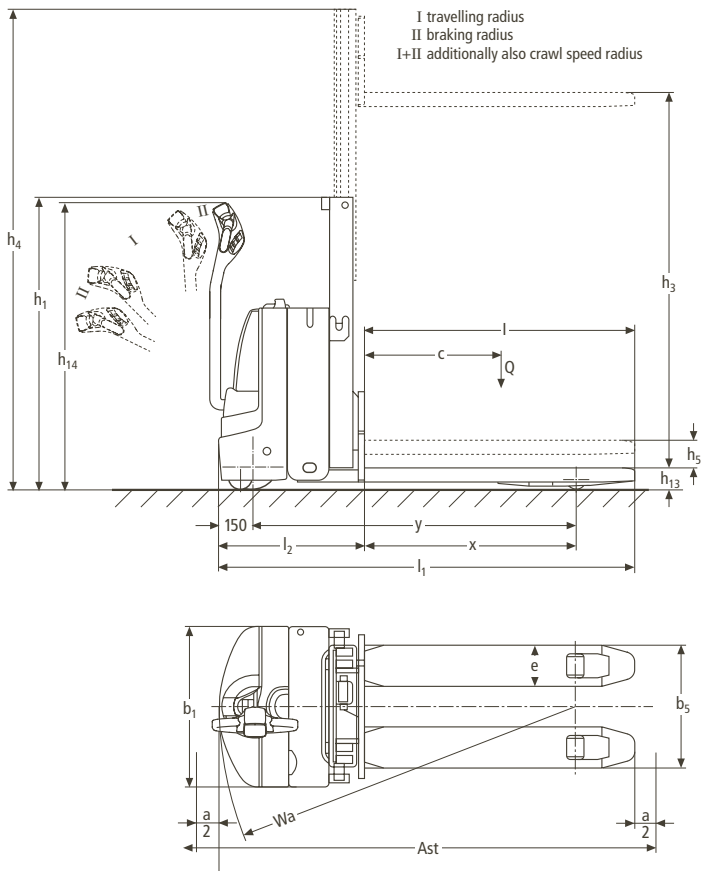

# Technical Data in line with VDI 2198 as at: 10/2006

Identification	1.1	Manufacturer (abbreviation)	Jungheinrich	1.1	
	1.2	Manufacturer's type designation	<b>EJD K18</b>	1.2	
	1.3	Drive (electric – battery or mains, diesel, petrol, fuel gas, manual)	electric	1.3	
	1.4	Type of operation (hand, pedestrian, standing, seated, order picker)	pedestrian	1.4	
	1.5	Load capacity / rated load	Q (t)	1.8	1.5
		Load capacity at mast lift	Q (t)	1 <sup>9)</sup>	
		Load capacity at support arm lift	Q (t)	1.8 <sup>9)</sup>	
	1.6	Load centre distance	c (mm)	600	1.6
	1.8	Load distance, centre of drive axle to fork	x (mm)	870 <sup>1)</sup>	1.8
1.9	Wheelbase	y (mm)	1400/1470 <sup>1)</sup>	1.9	
Weights	2.1	Service weight incl. battery (see line 6.5)	kg	754 <sup>2)</sup>	2.1
	2.2	Axle loading, laden front/rear	kg	877/1677 <sup>3)</sup>	2.2
	2.3	Axle loading, unladen front/rear	kg	544/210 <sup>4)</sup>	2.3
Wheels, Chassis	3.1	Tyres (solid rubber, superelastic, pneumatic, polyurethane)	Vulkollan®	3.1	
	3.2	Tyre size, front	230x70	3.2	
	3.3	Tyre size, rear	85x100	3.3	
	3.4	Additional wheels (dimensions)	100x40	3.4	
	3.5	Wheels, number front/rear (x = driven wheels)	1x+2/2	3.5	
	3.6	Track width, front	b <sub>10</sub> (mm)	464	3.6
	3.7	Track width, rear	b <sub>11</sub> (mm)	370	3.7
Basic Dimensions	4.2	Lowered mast height	h <sub>1</sub> (mm)	1295	4.2
	4.4	Lift height	h <sub>3</sub> (mm)	1660	4.4
	4.5	Extended mast height	h <sub>4</sub> (mm)	2250	4.5
	4.6	Initial lift	h <sub>5</sub> (mm)	125	4.6
	4.9	Height of tiller in drive position min./max.	h <sub>14</sub> (mm)	800/1230	4.9
	4.15	Lowered height	h <sub>13</sub> (mm)	90	4.15
	4.19	Overall length	l <sub>1</sub> (mm)	1840/1910 <sup>5)</sup>	4.19
	4.20	Length to face of forks	l <sub>2</sub> (mm)	650/720 <sup>5)</sup>	4.20
	4.21	Overall width	b <sub>1</sub> /b <sub>2</sub> (mm)	700/–	4.21
	4.22	Fork dimensions	s/e/l (mm)	65 x 190 x 1190	4.22
	4.24	Fork carriage width	b <sub>3</sub> (mm)	180	4.24
	4.25	Width over forks	b <sub>5</sub> (mm)	550	4.25
	4.31	Ground clearance, laden, under mast	m <sub>1</sub> (mm)	30	4.31
	4.33	Aisle width for pallets 1000 x 1200 crossways	Ast (mm)	2269/2339 <sup>6)</sup>	4.33
	4.34	Aisle width for pallets 800 x 1200 lengthways	Ast (mm)	2189/2259 <sup>7)</sup>	4.34
4.35	Turning radius	Wa (mm)	1470/1540 <sup>1)</sup>	4.35	
Performance Data	5.1	Travel speed, laden/unladen	km/h	5.0/5.2	5.1
	5.2	Lift speed, laden/unladen	m/s	0.12/0.22	5.2
	5.3	Lowering speed, laden/unladen	m/s	0.24/0.17	5.3
	5.8	Max. gradient performance, laden/unladen	%	6/12	5.8
	5.10	Service brake		electric	5.10
E-Motor	6.1	Drive motor rating S <sub>2</sub> 60 min.	kW	1	6.1
	6.2	Lift motor rating at S <sub>3</sub> 15 %	kW	2.2	6.2
	6.3	Battery acc. to DIN 43531/35/36 A, B, C, no		short – no/long – B	6.3
	6.4	Battery voltage, nominal capacity K <sub>s</sub>	V/Ah	24-130 (150); 24-180 (230)	6.4
	6.5	Battery dimensions	kg	138 <sup>8)</sup>	6.5
Others	8.1	Type of drive control		3-phase AC technology	8.1
	8.4	Sound level at driver's ear according to EN 12 053	dB (A)	70	8.4

- 1) short/long; load section lowered: + 55 mm  
 2) with long battery compartment (180 Ah): 796 kg  
 3) with long battery compartment (180 Ah): 905 kg/1691 kg  
 4) with long battery compartment (180 Ah): 572 kg/224 kg  
 5) short/long  
 6) Ast according to VDI diagonal method; lowered + 21 mm  
 7) Ast according to VDI diagonal method; lowered + 27 mm  
 8) with long battery compartment (180 Ah): 180 kg  
 9) in double-deck operation: mast lift 0.8 t support arm lift 1 t

# Make use of the advantages

## Innovative 3-phase AC technology

Jungheinrich motors in 3-phase AC technology give more productivity while reducing operating costs. Make use of these advantages:

- High performance with excellent energy management.
- Powerful acceleration.
- Quick travel direction change.
- No carbon brushes – the drive motor is maintenance-free.
- 2-year warranty on drive motor.

## Flexible application

Various applications make the EJD so economical:

- As a horizontal mover ideal for intensive utilisation over short transport distances.
- As a double-deck truck transporting two Euro pallets stacked on top of each other (support arm lift 1000 kg/mast lift 800 kg).
- Also most suitable for tight applications in shops, narrow warehouse areas or for loading and unloading lorries with its short chassis length of only 650 mm.

## Comfortable travel

The Jungheinrich drive control "SpeedControl" gives smooth, safe operation with adjustment for every application:

- The speed set on the drive switch is maintained in every travel situation – even on upward and downward gradients.
- Regenerative braking.
- Individually adjustable travel parameters (acceleration, top speed, electric brake) are adjustable to every requirement.
- Choice of three different travel programs (optional).



Multi-function tiller head

## Long operating times

Energy-saving 3-phase AC technology in combination with battery capacities up to 230 Ah ensures long operating times.

- Short version: 2 PzB 150 Ah.
- Long version: 2 PzS 180/230 Ah.

## Well-informed at any time

A large operator display provides information at a glance:

- Battery discharge indicator (two-coloured luminous diode) with lift stop.
- Information display "CanDis" (optional) with additional operating hour display and fault code memory.
- Truck activation via PIN and selection of three travel programs via CanCode (optional).

## Optimum cornering ability

Sprung, hydraulically cushioned support wheels – connected via "ProTracLink" – distribute the force dependent on the travel situation: evenly over all wheels for straight travel and concentrated on the outer support wheel on cornering.

## Reduced maintenance work.

3-phase AC technology in particular ensures low operating costs:

- Maintenance-free 3-phase AC drive motor without carbon brushes.
- Easy access to all components via a one-piece front cover fastened with only two screws.
- Protection against dust and damp through encapsulated steering and plugs according to IP 54.

## Options

- Information display CanDis.
- Keyless access via CanCode.
- Pen holder.
- Tandem load wheels.
- Integrated charger.



Integrated charger

## Jungheinrich UK Ltd.

Head Office:

Sherbourne House · Sherbourne Drive  
Tilbrook · Milton Keynes MK7 8HX  
Phone 01908 363100  
Fax 01908 363180

info@jungheinrich.co.uk  
www.jungheinrich.co.uk

Jungheinrich AG  
ISO 9001, ISO 14001  
Certification of Quality and  
Environment Management.



Jungheinrich trucks  
conform to the European  
Safety Requirements.



**JUNGHEINRICH**  
Well worthwhile