

Low lift truck with additional mast lift for comfortable order picking and stacking

Powerful thanks to maintenance-free 3-phase AC drive motor

Manoeuvrable and compact thanks to the short chassis length

Fully manoeuvrable with tiller in upright position due to crawl speed button

Integrated charger for easy charging at any mains socket (optional)



EJE C20

Electric pedestrian pallet truck (2,000 kg)

The EJE C20 is a pedestrian pallet truck which can also be used for order picking and light stacking operations. In addition to the support arm lift the load can be raised to an overall height of 752 mm via a simplex mast contained in the battery compartment. This allows the operator for example to pick goods at a comfortable height.

Light stacking operations, such as stacking half Euro pallets, can be easily undertaken with the separate support arm and mast lift (optional). The support arm lift capacity is 2000 kg while the

mast lift capacity is 700 kg.

There is also a powerful AC drive motor. The efficiency of this motor ensures high speeds and excellent acceleration with low energy consumption ideal for high productivity.

The operator has everything under control at all times, thanks to the low mounted long tiller. This provides sufficient distance between the operator and the truck. Especially when cornering the EJE C20 never gets too close to the operator. If space is at a premium, the

crawl speed button makes travelling safe with the tiller in the upright position. A touch of the button is sufficient: The brake is released and activation of the travel switch automatically reduces the speed of travel.

The re-designed multi-functional tiller arm is full of innovations: Sealed sensor system (IP 65) for maximum breakdown protection, rocker switches with contactless electronics for precise operation in any tiller position, ergonomically arranged switches.

EJE C20

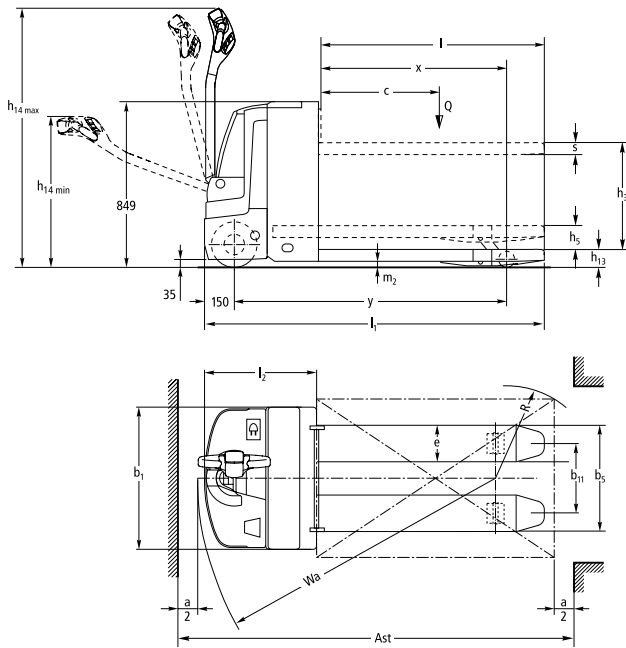

Vertical battery removal

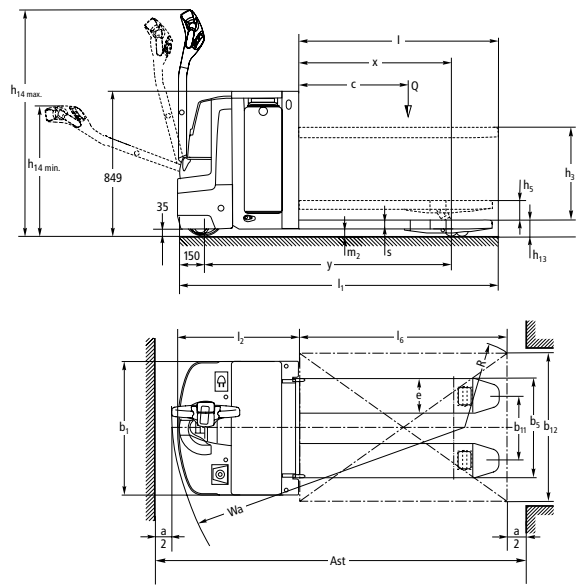

Sideways battery removal



Technical data in line with VDI 2198

Identification	1.1	Manufacturer (short form)		Jungheinrich
	1.2	Model		EJE C20
	1.3	Drive		Electrics
	1.4	Manual, pedestrian, stand-on, seated, order picker operation		pedestrian
	1.5	Load capacity/rated load	Q t	2
	1.5.1	Load capacity/mast lift	Q t	0.7
	1.5.2	Load capacity/support arm lift	Q t	2
	1.6	Load centre distance	c mm	600
	1.8	Load distance	x mm	903 ³⁾
1.9	Wheelbase	y mm	1480 ³⁾	
Weights	2.1.1	Net weight incl. battery (see row 6.5)	kg	555
	2.2	Axle load, w. load, front / rear	kg	860 / 1695
	2.3	Axle load, w.o. load, front / rear	kg	425 / 130
Wheels / chassis	3.1	Tyres		PU/PU
	3.2	Tyre size, at front	mm	Ø 230 x 70
	3.3	Tyre size, at rear	mm	Ø 82 x 100
	3.4	Additional wheels (dimensions)	mm	Ø 100 x 40
	3.5	Wheels, number front/rear (x = driven wheels)		1x +2/2 or 4
	3.6	Track width, front	b ₁₀ mm	508
	3.7	Track width, rear	b ₁₁ mm	343
Basic dimensions	4.4	Lift	h ₃ mm	540
	4.6	Initial lift	h ₅ mm	122
	4.9	Height of tiller in drive position min. / max.	h ₁₄ mm	797 / 1313
	4.15	Lowered height	h ₁₃ mm	90
	4.19	Overall length	l ₁ mm	1734
	4.20	Length incl. back of forks	l ₂ mm	584
	4.21	Total width	b ₁ /b ₂ mm	720
	4.22	Fork dimensions	s/e/l mm	60 / 187 / 1150
	4.25	Width over forks	b ₅ mm	540
	4.32	Floor clearance centre wheelbase	m ₂ mm	30
	4.33	Aisle width for pallets 1000 x 1200 sideways	Ast mm	1968 ²⁾
4.34	Aisle width for pallets 800 x 1200 lengthways	Ast mm	2018 ¹⁾	
4.35	Turning radius	W _s mm	1521 ³⁾	
Performance data	5.1	Travel speed, w. / w.o. load	km/h	6 / 6
	5.2	Lift speed, w. / w.o. load	m/s	0.12 / 0.17
	5.3	Lower speed, w. / w.o. load	m/s	0.13 / 0.2
	5.8	Max. gradeability, laden/unladen	%	8 / 20
	5.10	Service brake		electric
Electrics	6.1	Drive motor rating S2 60 min.	kW	1.0
	6.2	Lift motor rating at S3 10%	kW	1.2
	6.3	Battery according to DIN 43531/35/36 A,B,C, no		nein/B
	6.4	Battery voltage/nominal capacity K5	V/Ah	24 / 150
	6.5	Battery weight	kg	151
	6.6	Energy consumption according to VDI cycle	kWh/h	0.44
Misc.	8.1	Type of drive control		AC SpeedControl
	8.4	Sound pressure level at operator's ear according to EN 12053	dB (A)	70

¹⁾ Load section lowered: + 55 mm; diagonal in accordance with VDI + 202 mm

²⁾ Load section lowered: + 55 mm; Diagonal to VDI + 367 mm

³⁾ Load section raised / lowered: + 55 mm

Benefit from the advantages



In operation in a store

Innovative 3-phase AC technology

Jungheinrich 3-phase AC motors offer greater performance whilst at the same time reducing operating costs over the entire life of the truck:

- High efficiency levels with excellent energy management.
- Powerful acceleration.
- Stepless smooth control of the travel speed via the travel switch.
- Rapid travel direction change without pause.
- No carbon brushes – maintenance-free drive motor.
- Two year warranty on the drive motor.

Optimum cornering

Sprung and hydraulically cushioned support wheels linked via the ProTracLink torsion bar – distribute equalising forces dependent on travel conditions i.e. evenly across all wheels during straight-line travel; concentrated on the outer support wheel during cornering.

Fully informed at all times

Extensive instrument display and setting options allow the operator to monitor the situation at a glance:

- Discharge indicator (3 colour LED) with lift cut-out.
- Adjustable drive parameters through CanDis and CanCode (optional).
- CanDis information display (optional) with additional service hour display and service data storage.

- PIN activation of truck and choice of 3 travel programmes via CanCode (optional).

Comfortable operation

The SpeedControl impulse control system facilitates comfortable, safe travel:

- The speed set by the drive switch is maintained under all travel conditions – even on gradients / descents.
- If the EJE C20 starts to roll away on the ramp it brakes automatically.
- Individually adjustable drive parameters (acceleration, top speed, motor brake) enable the truck to be tailored to individual requirements.
- The operator may choose from 3 different travel programs (optional).
- Energy recovery through regenerative braking on deceleration.
- Very low noise level when travelling.

Reduced maintenance costs

Service-friendly components ensure a significant long-term reduction in operating costs:

- Maintenance-free AC drive motor with no carbon brushes.
- Easy access to all parts with one-piece front panel with just 2 screws.
- Excellent protection against dust and humidity through enclosure of controller and connectors to IP 54.

- The ProtracLink technology reduces tyre wear when operating on a ramp due to equalising effect of the torsion bar. This bar also keeps the support wheels at the same height and when they go over the edge of a loading dock or dock-leveller, unlike a spring loaded wheel they easily drive back into safety.

Optimum pallet handling

- Enclosed skids on both fork tips for easy entry into empty Euro or perimeter based pallets.
- Separate control of mast and support arm lift to remove semi / quarter pallets from Euro pallets (option).

Long uptimes

The energy-saving 3-phase AC system combined with a 250 Ah battery capacity ensures long operation times:

- 2 PzB 200 Ah batteries for vertical battery removal.
- Sideways battery removal (optional) for 2 PzB 250 Ah batteries.
- On-board charger (24V/30 A for wet cell batteries and maintenance-free batteries) for easy charging at any mains socket (optional).

Optional equipment

- Writing pad with light
- Load backrest.
- Special key switch for easy brake release.
- Cold store version.

Jungheinrich
Vertrieb Deutschland AG & Co. KG

Am Stadtrand 35
D-22047 Hamburg
Telephone +49 40 6948-0
Telefax +49 40 6948-1777

info@jungheinrich.com
www.jungheinrich.com

The German production facilities in Norderstedt and Moosburg are certified. **ISO 9001**
ISO 14001

Jungheinrich fork lift trucks meet European safety requirements.



JUNGHEINRICH
Machines. Ideas. Solutions.