

Shock-Protect provides vibration damping to protect the operator, truck and load

Maintenance-free 3-phase AC drive motor provides rapid acceleration and high speed

Compact design ensures flexibility and manoeuvrability

Outstanding stability and optimal driving characteristics thanks to ProTracLink

Multi-shift operation facilitated by sideways battery exit (optional)



ERE 120/C20

Electric pedestrian pallet truck (2,000 kg)

Use the ERE 120 to increase the productivity of your goods transport. Thanks to the high speed it reaches in ride-on mode, goods can be handled efficiently, comfortably transported over longer distances and also picked as required.

Thanks to its compact design, the ERE 120 combines the manoeuvrability of a pedestrian truck with the speed of a ride-on truck, enabling you to improve the efficiency of your operations. In addition there is the 24 V 3-phase AC drive motor. Its improved efficiency ensures powerful acceleration and high speeds combined with low consumption levels.

Of particular note are the superior safety features as well as the

optimum operator comfort in any situation:

- In addition to the soft sprung, folding platform, the entire drive system is cushioned with a ShockProtect suspension. The advantage: The vibrations and stress on the operator, goods and truck are significantly reduced.
- Safe travelling position when driving due to optional side restraints. These enable a higher speed of 8.5 km/h to be reached when transporting goods over longer distances.

If they are to be used intensively over longer distances or for loading and unloading HGVs, batteries with a capacity of up to 375 Ah are available as well as the option of lateral battery exchange (optional) for multi-shift operation.

ERE 120/C20

ERE 120

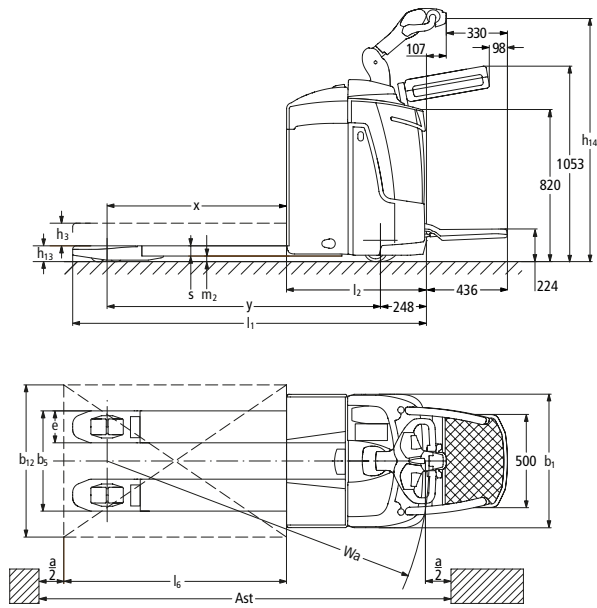

ERE 120 Option: ERE C20

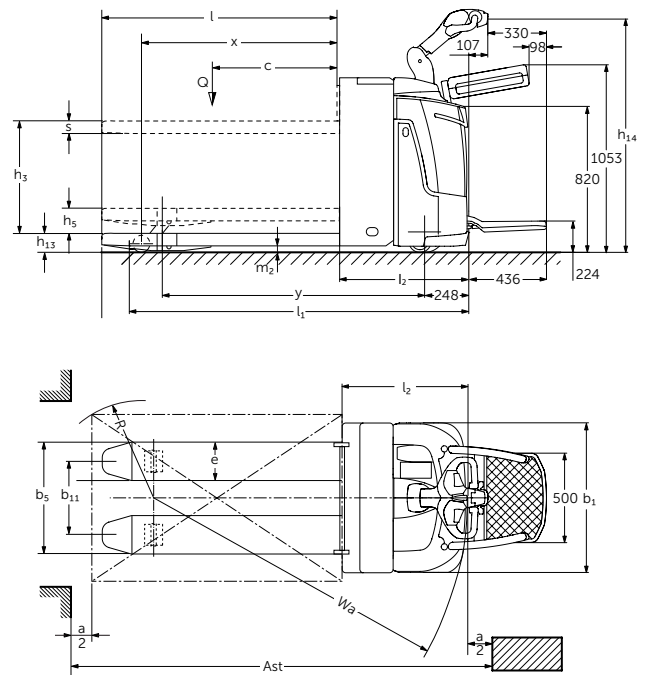

Technical data in line with VDI 2198

				Jungheinrich			
				ERE 120	ERE 120 Option: ERE C20		
Identification	1.1	Manufacturer (short form)					
	1.2	Model					
	1.3	Drive		Electrics			
	1.4	Manual, pedestrian, stand-on, seated, order picker operation		stand-on/pedestrian			
	1.5	Load capacity/rated load	Q	t	2		
	1.6	Load centre distance	c	mm	600		
	1.8	Load distance	x	mm	913 ⁴⁾	903 ⁴⁾	
	1.9	Wheelbase	y	mm	1,347 / 1,419 ⁴⁾⁶⁾	1,356 ⁴⁾	
	Weights	2.1	Service weight		432	503	
2.1.1		Net weight incl. battery (see row 6.5)		662	654		
2.2		Axle load, w. load front / rear		1,485 / 1,292	1,258 / 1,399		
2.3		Axle load w.o. load front / rear		189 / 588	128 / 525		
Wheels / frame	3.1	Tyres		Vulkollan/PU + quartz / Vulkollan			
	3.2	Tyre size, at front		Ø 230 x 70			
	3.3	Tyre size, at rear		Ø 85 x 100 / Ø 85 x 85	Ø 85 x 85 / Ø 85 x 100		
	3.4	Additional wheels (dimensions)		Ø 125 x 54			
	3.5	Wheels, number front/rear (x = driven wheels)		1x +2/2 or 4			
	3.6	Tread width, front	b ₁₀	mm	500	508	
	3.7	Tread width, rear	b ₁₁	mm	338 / 368 / 498	500	
Basic dimensions	4.4	Lift		h ₃	mm	122	540
	4.6	Initial lift		h ₅	mm	0	122
	4.9	Height of tiller in drive position min. / max.		h ₁₄	mm	1,146 / 1,428	
	4.15	Lowered height		h ₁₃	mm	85	90
	4.19	Overall length		l ₁	mm	1,834 ⁶⁾	1,850
	4.19.1	total length (long)			mm	1,906	0
	4.20	Length incl. back of forks		l ₂	mm	682 / 754 ⁶⁾	700
	4.21	Total width		b ₁ /b ₂	mm	720	
	4.22	Fork dimensions		s/e/l	mm	55 / 172 / 1,150	60 / 187 / 1,150
	4.25	Width over forks		b ₅	mm	540 ¹⁾	
	4.32	Floor clearance centre wheelbase		m ₂	mm	30	
	4.33	Aisle width for pallets 1000 x 1200 sideways		Ast	mm	2,032 / 2,104 ³⁾⁴⁾⁵⁾	2,114 ³⁾⁴⁾⁵⁾
4.34	Aisle width for pallets 800 x 1200 lengthways		Ast	mm	2,082 / 2,154 ²⁾⁴⁾⁵⁾	2,164 ²⁾⁴⁾⁵⁾	
4.35	Turning radius		W _a	mm	1,595 / 1,688 ⁴⁾	1,614 / 1,688 ⁴⁾	
4.35.2	turning radius in crawl speed			mm	1,667	0	
Performance data	5.1	Travel speed, w. / w.o. load		km/h	7.5 / 8.5	6 / 6	
	5.2	Lift speed, w. / w.o. load		m/s	0.04 / 0.04	0.16 / 0.27	
	5.3	Lowering speed, laden/unladen		m/s	0.06 / 0.08	0.17 / 0.15	
	5.7	Gradeability laden/unladen		%	3 / 6		
	5.8	Max. gradeability, w. / w.o. load		%	8 / 16		
	5.10	Service brake			generated		
Electrics	6.1	Drive motor rating S2 60 min.		kW	1.6		
	6.2	Lift motor rating at S3 10%		kW	2.2		
	6.3	Battery as per DIN 43531 /35/36 A, B, C, no			B		
	6.4	Battery voltage/nominal capacity K5		V/Ah	24 / 250	24 / 150	
	6.5	Battery weight		kg	230	151	
	6.6	Energy consumption according to VDI cycle		kWh/h	0.47	1.45	
Misc.	8.1	Type of drive control			impulse control system		
	8.4	Sound pressure level at operator's ear according to EN 12053		dB (A)	73		

¹⁾ additional dimensions available

²⁾ Diagonal according to VDI: + 204 mm

³⁾ Diagonal in accordance with VDI: + 368 mm

⁴⁾ Load section lowered: 55 mm

⁵⁾ With platform folded down: + 436 mm

⁶⁾ With side battery removal: + 72.5 mm

Benefit from the advantages



ERE 120

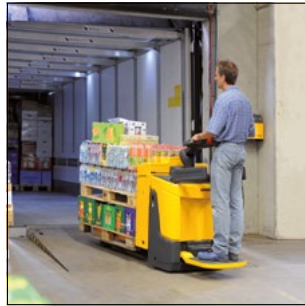

Comfortable loading and unloading



Option ERE C20



Display and access instrumentation

Intelligent control and powerful 3-phase AC motor

The ERE is equipped with a 3-phase AC drive motor, offering greater performance while simultaneously reducing operating costs. Make the most of these advantages:

- High level of efficiency with excellent energy management.
- Powerful acceleration and high speed.
- Rapid change in direction
- No rolling back on gradients.
- Maintenance-free drive motor.
- Energy recovery through regenerative braking on deceleration.

The truck model can be adapted to the application profile

The truck is available in a number of different models, offering flexible application opportunities:

Model 1: Folding stand-on platform without restraint system

- Pedestrian mode.
- Speed of 4.5 km/h when stand-on platform is folded up.
- Speed of 6 km/h when stand-on platform is folded down.

Model 2: Folding stand-on platform with restraint system (optional)

- Pedestrian/ride-on mode.
- Speed of 4.5 km/h when stand-on platform is folded up and restraint system retracted.
- Speed of 6 km/h when stand-on platform is folded down and restraint system retracted.

- Speed of 8.5 km/h when stand-on platform is folded down and restraint system folded out.

Comfortable riding and ergonomic order picking

The ergonomic lift of the ERE C20 (optional) simplifies and accelerates order picking. Adjusting the lift height optimises order picking and light stacking operations.

Make the most of the advantages:

- Comfortable height for order picking reduces strain on the back.
- Comfortable riding over short and medium distances.
- Use as a work table (752 mm high).
- Transports loads of up to 2000 kg (initial lift) or 700 kg in mast lift.

Optimum driving characteristics

- ProTracLink: Sprung and cushioned support wheels – linked via a torsion bar – ensure safe handling in all driving conditions.
- ShockProtect: Additional sprung suspension provides protection for the operator, truck and load. Optimally adjusted to the load, the suspension cushions the operator and frame against harder impacts.

Everything at a glance

The optimally configured controls provide the operator with all the information required at a glance at any time:

- CanDis provides information on battery charge status, hourmeter and service code storage (optional).
- CanCode facilitates activation of the truck via PIN, with the opportunity to individually specify authorised operators (optional).
- The adjustment options for the drive parameter settings allow for optimum adaptation to any application (optional).

Reduced maintenance costs

Service-friendly components and ease of access reduce operating costs:

- Easily removable components allow for ease of access to the units.
- Maximum speed only possible when forks are raised (optional). This reduces wear beneath the forks.

Long operating times

Battery capacities of up to 375 Ah guarantee long operating times:

- Battery compartment M: 180 / 250 Ah.
- Battery compartment L: 300 / 375 Ah.
- Lateral battery exchange for both battery compartments (optional).

Additional equipment

- Entry skids and entry rollers.
- Load guard.
- Cold store model.

Jungheinrich Aktiengesellschaft

Am Stadtrand 35
D-22047 Hamburg
Telephone +49 40 6948-0
Telefax +49 40 6948-1777

info@jungheinrich.com
www.jungheinrich.com

The German production facilities in Norderstedt and Moosburg are certified. **ISO 9001**
ISO 14001

Jungheinrich fork lift trucks meet European safety requirements.



JUNGHEINRICH
Machines. Ideas. Solutions.