

Innovative work station for relaxed and safe operation

Powerful 3-phase AC drive motor for maximum performance

ShockProtect to protect the operator, truck and load

SmartPilot electric tiller steering for precise and easy steering

Curve Control for added safety when cornering

Folding stand-on platform (optional)



## ERE 225

### Electric powered pallet truck (2,500 kg)

The ERE 225 is the perfect truck for high-performance loading and unloading of HGVs as well as the rapid transport of heavy loads over longer distances. Due to the higher speeds, in comparison with normal pedestrian trucks, goods can be handled or transported particularly efficiently.

The workstation is optimally configured to suit the needs of the operator:

- Innovative control concept for equally safe travel forward or reverse.
- Extra-high sides to the operator compartment ensure exceptional operator protection.

- A variety of storage options as well as a height-adjustable tiller (optional) ensures ergonomic and fatigue-free operation of the truck across the entire shift.

The truck also offers safety and driving comfort in every situation:

- In addition to the soft suspension of the stand-on platform, the entire drive system is cushioned with ShockProtect suspension.
- ShockProtect ensures that the stand-on platform is cushioned against impacts. The advantage: Reduces stress on the operator's spinal column. Considerably less impact on the frame and all technical components of the ERE 225.

- Maximum safety is guaranteed, especially during demanding situations or when frequent journeys are made in reverse, by the enclosed sides and fixed stand-on platform.
- The maximum speed of the truck is automatically reduced when cornering, depending on the steering angle (Curve Control).

Up to 465 Ah high-performance batteries are available for really demanding applications. For multi-shift operations, the ERE 225 is available with lateral battery exchange (optional). If the truck is to be used in very confined spaces, a version with a folding platform is available (optional).

# ERE 225

ERE 225

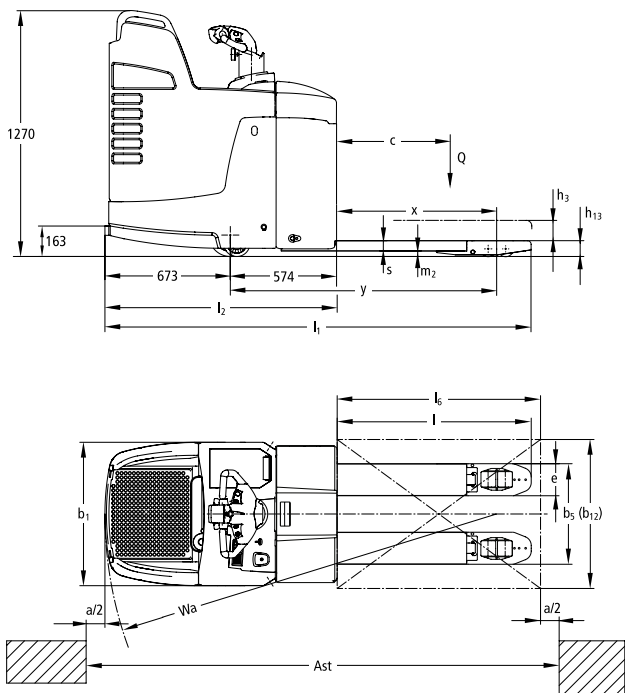

Fixed platform

ERE 225

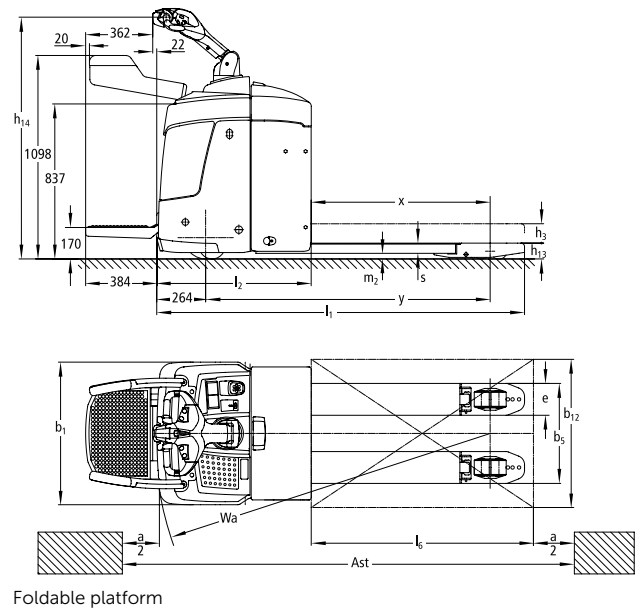

Foldable platform



# Technical data in line with VDI 2198

Identification	1.1	Manufacturer (short form)		Jungheinrich	
	1.2	Model		ERE 225	
	1.3	Drive		Electrics	
	1.4	Manual, pedestrian, stand-on, seated, order picker operation		stand-on	stand-on/pedestrian
	1.5	Load capacity/rated load	Q t	2.5	
	1.6	Load centre distance	c mm	600	
	1.8	Load distance	x mm	911 <sup>4)</sup>	
	1.9	Wheelbase	y mm	1484 <sup>4)6)</sup>	
	Weights	2.1.1	Net weight incl. battery (see row 6.5)	kg	850
2.2		Axle load, w. load, front / rear	kg	2090 / 1260	2187 / 1105
2.3		Axle load, w.o. load, front / rear	kg	150 / 770	158 / 634
Wheels / chassis	3.1	Tyres		Vulkollan	
	3.2	Tyre size, at front	mm	Ø 230 x 77	
	3.3	Tyre size, at rear	mm	Ø 85 x 110 / Ø 85 x 85	
	3.4	Additional wheels (dimensions)	mm	Ø 140 x 57	
	3.5	Wheels, number front/rear (x = driven wheels)		1x +2/2 or 4	
	3.6	Track width, front	b <sub>10</sub> mm	513	
	3.7	Track width, rear	b <sub>11</sub> mm	338 / 368 / 498	
Basic dimensions	4.4	Lift	h <sub>3</sub> mm	122	
	4.9	Height of tiller in drive position min. / max.	h <sub>14</sub> mm	1267	1158 / 1414
	4.15	Lowered height	h <sub>13</sub> mm	85	
	4.19	Overall length	l <sub>1</sub> mm	2397 <sup>6)</sup>	1986 <sup>6)</sup>
	4.20	Length incl. back of forks	l <sub>2</sub> mm	1247 <sup>6)</sup>	834 <sup>6)</sup>
	4.21	Total width	b <sub>1</sub> /b <sub>2</sub> mm	770	
	4.22	Fork dimensions	s/e/l mm	55 / 172 / 1150	
	4.25	Width over forks	b <sub>5</sub> mm	540 <sup>1)</sup>	
	4.32	Floor clearance centre wheelbase	m <sub>2</sub> mm	30	
	4.33	Aisle width for pallets 1000 x 1200 sideways	Ast mm	2699 <sup>3)5)6)</sup>	2253 <sup>3)5)6)</sup>
4.34	Aisle width for pallets 800 x 1200 lengthways	Ast mm	2749 <sup>3)5)6)</sup>	2300 <sup>2)5)6)</sup>	
4.35	Turning radius	W <sub>a</sub> mm	2260 <sup>4)5)6)</sup>	1812	
Performance data	5.1	Travel speed, w. / w.o. load	km/h	9.5 / 12.5	
	5.2	Lift speed, w. / w.o. load	m/s	0.05 / 0.06	
	5.3	Lower speed, w. / w.o. load	m/s	0.055 / 0.04	
	5.8	Max. gradeability, laden/unladen	%	8 / 16	
	5.10	Service brake		electric	
Electrics	6.1	Drive motor rating S2 60 min.	kW	2.8	
	6.2	Lift motor rating at S3 10%	kW	2.2	
	6.3	Battery according to DIN 43531/35/36 A,B,C, no		B	
	6.4	Battery voltage/nominal capacity K5	V/Ah	24 / 375	
	6.5	Battery weight	kg	288	
	6.6	Energy consumption according to VDI cycle	kWh/h	0.59	
Misc.	8.1	Type of drive control		AC SpeedControl	
	8.4	Sound pressure level at operator's ear according to EN 12053	dB (A)	66	

<sup>1)</sup> additional dimensions available

<sup>2)</sup> Diagonal according to VDI: + 204 mm

<sup>3)</sup> Diagonal in accordance with VDI: + 368 mm

<sup>4)</sup> Load section lowered: 55 mm

<sup>5)</sup> With platform folded down: + 384 mm

<sup>6)</sup> With side battery removal: + 72.5 mm

# Benefit from the advantages



Travel in drive direction with the ERE 225



ERE 225 with foldable stand-on platform



Comfortable workplace

## Powerful 3-phase AC drive motor and intelligent electronic controller

Progressive drive technology and control electronics (SpeedControl) ensure safe and energy saving operation with adjustment to every application:

- The speed set by the accelerator is maintained in every travel situation – even during climbing and descending gradients and slopes.
- The ERE 225 is protected against unintended rollback on ramps by automatic brake activation.
- Energy is returned to the battery during speed reduction using regenerative braking.

## Safer and more ergonomic operator compartment

The workplace is adjusted to fit operator and application requirements:

- New operator position: when travelling with the forks trailing, the operator can stand sideways and hold themselves steady with one hand on the tiller, and the other on the fixed platform handle, therefore maintaining full control of the vehicle at all times.
- The operator compartment is symmetrically arranged for easy operation by both right-handed and left-handed operators.
- Various storage areas for operator paperwork, clipboard etc.

## Foldable stand-on platform (optional)

- A choice of options pedestrian/ride-on operation.
- Reduced travel speeds; ride-on, when side protection/support arms are folded in (6 km/h) and in pedestrian operation (4 km/h).
- Minimum working area requirement.

## Optimum handling characteristics

- Sprung and cushioned support wheels connected via the torsion bar ProTracLink system, ensure safe handling in all situations.
- Jungheinrich ShockProtect: protection for operator, truck and load through additional suppression/suspension of the drive train. The suspension minimises shocks to the operator and chassis.

## Information at all times

Comprehensive control instrumentation gives the operator information at a glance at all times:

- CanDis information display (optional) with additional hourmeter and service code storage.

## Ergonomic steering

The newly developed tiller head is easily adjustable to the ergonomic needs of the operator.

- Clear colour coded buttons with abrasion resistant symbols for intuitive operation.
- Comfortable and well arranged operator compartment.
- Contactless sensor system protected in accordance with OP 65.
- Rocker switch for intuitive and safe operation of hydraulic functions.
- Height-adjustable tiller head (optional).

## Reduced maintenance

- Easy access to all components through an easily removable one-piece motor cover.
- Activation of maximum travel speed only by suitably raised forks ensures a reliable reduction in wear under the forks (optional).

## Longer times in operation

Battery capacities with up to 465 Ah ensure longer times in operation:

- Battery compartment L: 3 EPzS 375 Ah.
- Battery compartment L high: 3 EPzS 465 Ah.
- Side battery replacement (optional) for fast battery change in multi-shift applications.

## Additional equipment

- Entry rollers.
- Load protection frame.
- Cold store application.

**Jungheinrich**  
Vertrieb Deutschland AG & Co. KG

Am Stadtrand 35  
D-22047 Hamburg  
Telephone +49 40 6948-0  
Telefax +49 40 6948-1777

info@jungheinrich.com  
www.jungheinrich.com

The German production facilities in Norderstedt and Moosburg are certified. **ISO 9001**  
**ISO 14001**

Jungheinrich fork lift trucks meet European safety requirements.



**JUNGHEINRICH**  
Machines. Ideas. Solutions.