

Ideal for occasional stacking operations

Maintenance-free gel battery (no water replenishment)

Integrated battery charger for easy charging

Powerful lift motor



HC 110

Electric hand stacker (1000 kg)

The electric hand stacker HC 110 provides a cost-effective option for carrying out occasional stacking operations (1600 to 3000 mm lift height) and the loading and unloading of utility vehicles.

The manually operated HC 110 with its electric lift is also used in many areas as a worktable. The HC 110 draws its required energy from a maintenance-free gel battery.

An integrated charger facilitates easy and reliable charging of the integrated battery at any 230V mains socket.

HC 110

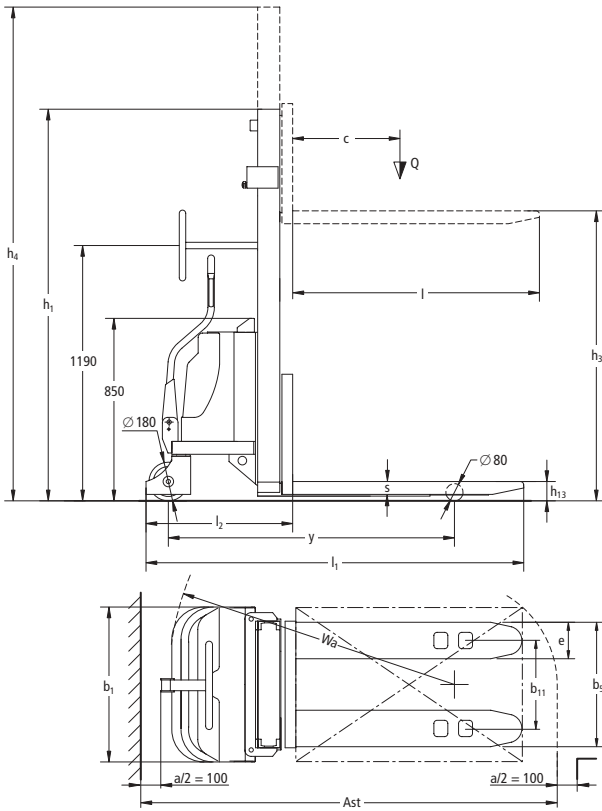

Technical Data in line with VDI 2198 as at: 09/2005

Identification	1.1	Manufacturer (abbreviation)		Jungheinrich	Jungheinrich	Jungheinrich	1.1
	1.2	Manufacturer's type designation		HC 110	HC 110	HC 110	1.2
		Lift height	(mm)	(1600)	(2500)	(3000)	
	1.3	Drive (electric – battery or mains, diesel, petrol, fuel gas, manual)		manual	manual	manual	1.3
	1.4	Type of operation (hand, pedestrian, standing, seated, order picker)		pedestrian	pedestrian	pedestrian	1.4
	1.5	Load capacity/rated load	Q (t)	1	1	1	1.5
	1.6	Load centre distance	c (mm)	600	600	600	1.6
	1.9	Wheelbase	y (mm)	1335	1335	1335	1.9
Weights	2.1	Service weight incl. battery (see line 6.5)	kg	289	378	398	2.1
Wheels, Chassis	3.1	Tyres (solid rubber, superelastic, pneumatic, polyurethane)		polyamide	polyamide	polyamide	3.1
	3.2	Tyre size, front		180x50	180x50	180x50	3.2
	3.3	Tyre size, rear		80x70	80x70	80x70	3.3
	3.5	Wheels, number front/rear (x = driven wheels)		1/1 1/1	1/1 1/1	1/1 1/1	3.5
	3.7	Track width, rear	b ₁₁ (mm)	410	410	410	3.7
Basic Dimensions	4.2	Lowered mast height	h ₁ (mm)	2100	1850	2100	4.2
	4.4	Lift height	h ₃ (mm)	1600	2500	3000	4.4
	4.5	Extended mast height	h ₄ (mm)	2100	3055	3550	4.5
	4.15	Lowered height	h ₁₃ (mm)	90	90	90	4.15
	4.19	Overall length	l ₁ (mm)	1755	1755	1755	4.19
	4.20	Length to face of forks	l ₂ (mm)	685	685	685	4.20
	4.21	Overall width	b ₁ /b ₂ (mm)	722/722	722/722	722/722	4.21
	4.22	Fork dimensions	s/e/l (mm)	21/170/1070	21/170/1070	21/170/1070	4.22
4.25	Width over forks	b ₅ (mm)	580	580	580	4.25	
4.33	Aisle width for pallets 1000 x 1200 crossways	Ast (mm)	2175	2175	2175	4.33	
4.34	Aisle width for pallets 800 x 1200 lengthways	Ast (mm)	2145	2145	2145	4.34	
Performance Data	5.2	Lift speed, laden/unladen	m/s	0.06/0.09	0.06/0.09	0.06/0.09	5.2
	5.3	Lowering speed, laden/unladen	m/s	0.16/0.14	0.16/0.14	0.16/0.14	5.3
5.11	Parking brake		manual	manual	manual	5.11	
E-Motor	6.2	Lift motor rating at S ₃ 15 %	kW	1.6	1.6	1.6	6.2
	6.4	Battery voltage, nominal capacity K ₅	V/Ah	12/70	12/100	12/100	6.4
6.5	Battery weight	kg	24	38	38		

Make use of the advantages

Cost-conscious and powerful

For occasional stacking and retrieval up to a lift height of 3000 mm, the HC 110 provides a cost-effective alternative compared with trucks fitted with a drive motor. It is able to deal with a large number of applications with its different mast options (1600, 2500, 3000 mm) and a powerful 1.6 kW lift motor. For instance, with the 1600 mm mast variant it is suitable for loading and unloading utility vehicles, for stacking two pallets on top of each other or as a worktable.



Clear arrangement of all operating and display elements



Easy access to emergency plug



Easy access to all components

Clear and precise operation

The electro-hydraulic lift control and easy accessibility of lifting and lowering function keys facilitate precise positioning of the forks. All operating and display instruments are clearly arranged.



Simple plug in at any 230 V mains socket

Comfortable battery charging

The often troublesome water replenishment is not necessary for the maintenance-free battery. The battery discharge indicator always shows the current state of the battery. The integrated high-frequency charger with charge condition display and the charge characteristic curve/charge maintainer optimally adjusted to the battery provide first-rate comfort and ensures charging at any 230V mains socket.

Safe and economic operation

- Easy handling through ergonomically arranged control handles.
- Effortless pulling during transport with long tiller.
- Additional protection for the operator through foot protection on the steering rollers.
- Safe parking in any situation with mechanical parking brake.

Jungheinrich UK Ltd.

Head Office:

Sherbourne House · Sherbourne Drive
Tilbrook · Milton Keynes MK7 8HX
Phone 01908 363100
Fax 01908 363150

info@jungheinrich.co.uk
www.jungheinrich.co.uk

ISO 9001, ISO 14001
Certification of Quality and
Environment Management.



Jungheinrich trucks
conform to the European
Safety Requirements.



JUNGHEINRICH
Well worthwhile