

All drives for travel, lifting and lowering in 3-phase AC technology

Space-saving through optimum truck geometry

Cockpit with ergonomic function design

Energy reclamation during braking and lowering (optional)

MULTI-PILOT control lever

Jungheinrich Curve Control for safer driving and cornering



ETM 320/ETV 320/ETM 325/ETV 325

Electric Reach Truck (2000, 2500 kg)

Space-saving design, high performance data and ergonomically optimised working conditions. These are the strengths of Jungheinrich Reach Trucks 320/325.

The advantages: Space-saving through narrow working aisle widths from 2804 mm (according to VDI when picking up Euro pallets lengthways). Higher throughput efficiency – at the same time reduction of service requirements – through constant use of 3-phase AC technology. Motivated, relaxed operators through efficiency-promoting operating ergonomics. The operator feels the benefit of comfort from the

start: from the lowered entry height he comfortably reaches the 3-fold adjustable comfort seat, adjustable armrest, MULTI PILOT control lever and vertically/ horizontally steplessly adjustable steering wheel.

By using the display/operating instruments arranged in front of him, he can call up all operational and safety-relevant data and individually adjust or select various travel programs. Arrangement and design of the instruments contribute towards safety as much as the excellent visibility through the panorama mast or operator-protecting roof.

The Jungheinrich reach trucks 320/325 thus provide the best preconditions for economic stacking and retrieval at high lift heights and in the most confined spaces. No matter whether for working in pallet, continuous or drive-in racking, whether for particularly narrow or low clearance heights, whether for single shift or multi-shift applications – the reach trucks 320/325 provide the ideal solution for every application.

ETM 320/ETV 320/ETM 325/ETV 325

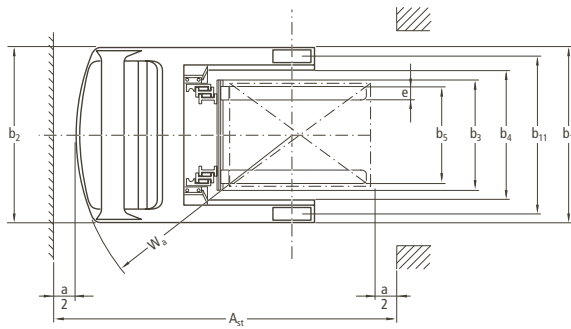
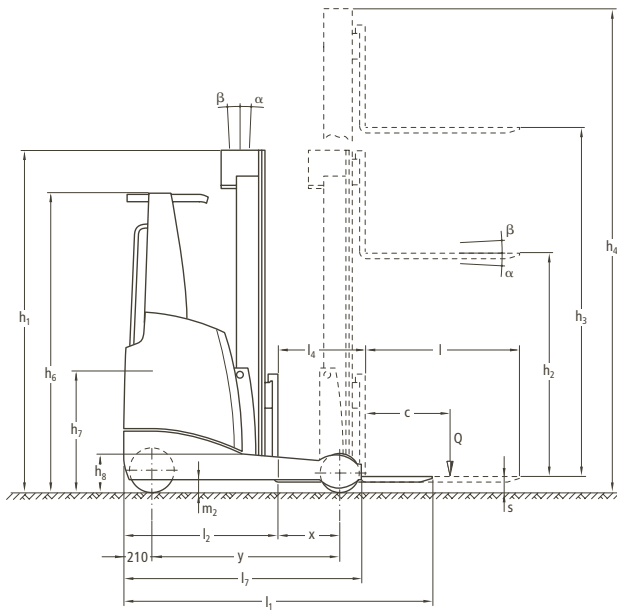

Capacity

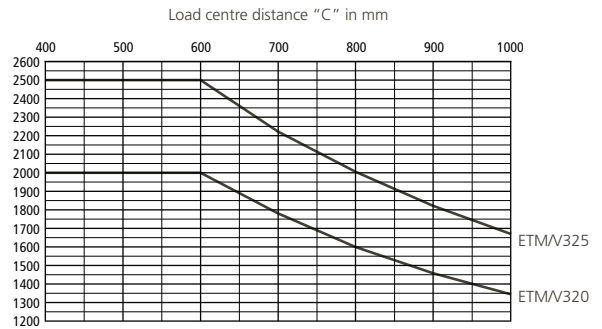

Mast Table ETM 320 / ETV 320 / ETM 325 / ETV 325						
Designation	Closed mast height h_1 mm	Lift height h_3 mm	Free lift h_2 mm	Extended mast height h_4 mm	Mast tilt forward/backward α°/β°	Fork tilt*) forward/backward α°/β°
Three-stage DZ	2050	4250	1320	4996	1/5	-
	2200	4700	1470	5446	1/5	-
	2300	5000	1570	5746	1/5	-
	2400	5300	1670	6046	1/5	-
	2480	5560	1750	6306	1/3	-
	2500	5600	1770	6346	1/3	-
	2600	5900	1870	6646	0.5/2	-
	2650	6050	1920	6796	0.5/2	-
	2700	6200	1970	6946	0.5/2	2/5
	2900	6800	2170	7546	0.5/2	2/5
	2950	6950	2220	7696	0.5/2	2/5
	3100	7400	2370	8146	0.5/1	2/5
	3300	8000	2570	8746	0.5/1	2/5
	3440	8420	2710	9166	0.5/1	2/5
	3540	8720	2810	9466	0.5/1	2/5
	3670	9110	2940	9856	-	2/5
	3840	9620	3110	10366	-	2/5
	3950	9950	3220	10696	-	2/5
	4040	10220	3310	10966	-	2/5
	4140	10520	3410	11266	-	2/5
4200	10700	3470	11446	-	2/5	
4260	10880	3530	11626	-	2/5	
4340	11120	3610	11866	-	2/5	
4470	11510	3740	12256	-	2/5	
4640	12020	3910	12766	-	2/5	

*) only ETV 320/325

Technical Data in line with VDI 2198 as at: 10/2006

Identification	1.1	Manufacturer (abbreviation)	Jungheinrich	Jungheinrich	Jungheinrich	Jungheinrich	1.1
	1.2	Manufacturer's type designation	ETM 320 DZ	ETV 320 DZ	ETM 325 DZ	ETV 325 DZ	1.2
		G = fork; E = integrated sideshift	GE	GE	GE	GE	
	1.3	Drive (electric – battery or mains, diesel, petrol, fuel gas, manual)	electric	electric	electric	electric	1.3
	1.4	Type of operation (hand, pedestrian, standing, seated, order picker)	seated	seated	seated	seated	1.4
	1.5	Load capacity/rated load Q (t)	2	2	2.5	2.5	1.5
	1.6	Load centre distance c (mm)	600	600	600	600	1.6
	1.8	Load distance, centre of drive axle to fork x (mm)	313 ¹⁾	401 ¹⁾	468 ¹⁾	501 ¹⁾	1.8
		Mast pushed forward x ₁ (mm)	223	223	223	223	
1.9	Wheelbase y (mm)	1512	1512	1667	1667	1.9	
Weights	2.1	Service weight kg	3550 ¹⁾	3650 ¹⁾	3600 ¹⁾	3700 ¹⁾	2.1
	2.3	Axle loading, unladen front/rear kg	2152/1398	2212/1438	2204/1396	2264/1436	2.3
	2.4	Axle loading, fork advanced, laden front/rear kg	572/4978	582/5068	592/5508	602/5598	2.4
	2.5	Axle loading, fork retracted, laden front/rear kg	1805/3745	1845/3805	1997/4103	2032/4168	2.5
Wheels, Chassis	3.1	Tyres: solid rubber, superelastic, pneumatic, polyurethane	Vulkollan®	Vulkollan®	Vulkollan®	Vulkollan®	3.1
	3.2	Tyre size, front	343 x 140	343 x 140	343 x 140	343 x 140	3.2
	3.3	Tyre size, rear	355 x 106	355 x 106	355 x 135	355 x 135	3.3
	3.5	Wheels, number front rear (x = driven wheels)	1x/2	1x/2	1x/2	1x/2	3.5
	3.6	Track width, front b ₁₀ (mm)	–	–	–	–	3.6
	3.7	Track width, rear b ₁₁ (mm)	1005	1155	1034	1184	3.7
Basic Dimensions	4.1	Mast/fork carriage tilt forward/backward α/β (°)	1/5 ²⁾	1/5 ²⁾	1/5 ²⁾	1/5 ²⁾	4.1
	4.2	Closed mast height h ₁ (mm)	2400	2400	2400	2400	4.2
	4.3	Free lift h ₂ (mm)	1670	1670	1670	1670	4.3
	4.4	Lift height h ₃ (mm)	5300	5300	5300	5300	4.4
	4.5	Extended mast height h ₄ (mm)	6046	6046	6046	6046	4.5
	4.7	Overhead load guard (cab) height h ₆ (mm)	2150	2150	2150	2150	4.7
	4.8	Seat height/standing height h ₇ (mm)	960	960	960	960	4.8
	4.10	Height of wheel arms h ₈ (mm)	355 ³⁾	355 ³⁾	355 ³⁾	355 ³⁾	4.10
	4.19	Overall length l ₁ (mm)	2547 ¹⁾	2459 ¹⁾	2547 ¹⁾	2547 ¹⁾	4.19
	4.20	Length to face of forks l ₂ (mm)	1397 ¹⁾	1309 ¹⁾	1397 ¹⁾	1364 ¹⁾	4.20
	4.21	Overall width b ₁ /b ₂ (mm)	1140/1120	1290/1270	1198/1120	1348/1270	4.21
	4.22	Fork dimensions s/e/l (mm)	50 x 140 x 1150	50 x 140 x 1150	50 x 140 x 1150	50 x 140 x 1150	4.22
	4.23	Fork carriage ISO 2328, class/type A, B	2/B	2/B	2/B	2/B	4.23
	4.24	Fork-carriage width b ₃ (mm)	800	800	800	800	4.24
	4.25	Width over forks b ₅ (mm)	356/737	356/737	356/737	356/737	4.25
	4.26	Distance between support arms/loading surfaces b ₄ (mm)	790	940	790	940	4.26
	4.28	Reach distance l ₄ (mm)	536 ¹⁾	624 ¹⁾	703 ¹⁾	736 ¹⁾	4.28
	4.32	Ground clearance, centre of wheelbase m ₂ (mm)	95	95	95	95	4.32
	4.33	Aisle width for pallets 1000x1200 crossways Ast (mm)	2822/2597 ⁴⁾	2758/2509 ⁴⁾	2867/2442 ⁴⁾	2845/2564 ⁴⁾	4.33
	4.34	Aisle width for pallets 800x1200 lengthways Ast (mm)	2883/2797 ⁴⁾	2804/2709 ⁴⁾	2899/2642 ⁴⁾	2870/2764 ⁴⁾	4.34
	Truck diagonal D (mm)	2092	2182	2237	2327		
4.35	Turning radius Wa (mm)	1710	1710	1865	1865	4.35	
4.37	Length across wheel arms l ₇ (mm)	1920	1920	2075	2075	4.37	
Performance Data	5.1	Travel speed, laden/unladen km/h	14/14	14/14	14/14	14/14	5.1
	5.2	Lift speed, laden/unladen m/s	0.32/0.60 ²⁾	0.32/0.60 ²⁾	0.30/0.60 ²⁾	0.30/0.60 ²⁾	5.2
	5.3	Lowering speed, laden/unladen m/s	0.5/0.5 ²⁾	0.5/0.5 ²⁾	0.5/0.5 ²⁾	0.5/0.5 ²⁾	5.3
	5.4	Reach speed, laden/unladen m/s	0.1 ²⁾	0.1 ²⁾	0.12 ²⁾	0.12 ²⁾	5.4
	5.7	Gradient performance, laden/unladen %	7/11	7/11	6/10	6/10	5.7
	5.8	Max. gradient performance, laden/unladen %	10/15	10/15	10/15	10/15	5.8
	5.9	Acceleration time, laden/unladen s	5.3/4.6	5.3/4.6	5.4/4.6	5.4/4.6	5.9
	5.10	Service brake	electric	electric	electric	electric	5.10
E-Motor	6.1	Drive motor rating S ₂ 60 min kW	6.9	6.9	6.9	6.9	6.1
	6.2	Lift motor rating at S ₃ 15% kW	10/14 ⁵⁾	10/14 ⁵⁾	10/14 ⁵⁾	10/14 ⁵⁾	6.2
	6.3	Battery acc. to DIN 43531/35/36 A, B, C, no	DIN 43531 (circuit B)	DIN 43531 (circuit C)	DIN 43531 (circuit B)	DIN 43531 (circuit C)	6.3
	6.4	Battery voltage, nominal capacity K _s V/Ah	48/560 ¹⁾	48/560 ¹⁾	48/560 ¹⁾	48/560 ¹⁾	6.4
	6.5	Battery weight kg	937 ¹⁾	937 ¹⁾	937 ¹⁾	937 ¹⁾	6.5
Other Details	8.1	Type of drive control	MOSFET Control/AC	MOSFET Control/AC	MOSFET Control	MOSFET Control	8.1
	8.2	Operating pressure for attachments bar	160	160	160	160	8.2
	8.3	Oil volume for attachments l/min	15	15	15	15	8.3
	8.4	Sound level at driver's ear according to EN 12053 dB(A)	70	70	70	70	8.4
<p>1) other battery sizes change these values 3) with load wheel covering +30 mm 5) without regenerative lowering 10 kW 2) dependent on mast 4) for floor storage</p>							

This specification sheet according to VDI regulation 2198 only provides technical values for the standard truck. Non-standard tyres, different masts, additional equipment, etc. could produce other values. Right reserved for technical changes and improvements.

Make use of the advantages

High-performance mast

Jungheinrich masts provide maximum safety and space utilisation to high lift heights:

- Excellent visibility towards load.
- Patented mast reach cushioning; in addition, the travel speed is automatically reduced to crawl speed if the load is raised above the free lift height.
- Integrated sideshift.
- Lowest clearance heights together with high lift heights.
- Choice of mast tilt or fork tilt.
- Extremely long lifespan through high-quality sections.
- High residual capacity to high lift heights.
- Lift heights up to 12020 mm.

Ergonomic operator cab

The operator compartment provides ideal working conditions for highest performance and ease of operation.

- Comfort seat adjustable to any driver (sitting position/backrest/body weight).
- Many depositing facilities.
- Important operating elements are accessible without reaching round.
- Generous available space.
- 3-phase AC steering (switch-over from 180° to 360° available) with optimised steering wheel position.
- Automatic positioning of sideshift (centre position) at the touch of a button (optional).



Ergonomic operator cab



MULTI-PILOT

- Automatic horizontal positioning of forks (with fork tilt) at the touch of a button (optional).

MULTI-PILOT Control Lever

Centrally positioned control lever to control all hydraulic functions, choice of travel direction and horn.

- All operating elements are within sight and each take up a clear function.
- No reaching round is required even during the use of additional hydraulic functions (e.g. fork adjuster, optional).
- Maximum throughput efficiency through simultaneous use of two hydraulic functions (e.g. lifting and reaching).
- Precise operation through proportional hydraulics for all functions.



Operator display

Operator Display

High-quality control instrument for the display of most important operating data.

- Travel direction and wheel position display.
- 180°-/360° steering mode.
- Battery condition with residual running time display.
- 3 application programs can be individually adapted to ensure optimal performance in any application.
- Operating hours and time.
- Lift height (optional).
- Centre position sideshift (optional).

Onboard Computer (optional)

The onboard computer combines several functions in one operating element that ensure economic performance and reliability during daily high-powered operations.

- Large colour screen (TFT-Display)
- PIN access entitlement with user administration.
- Speed display.
- Input of height selection for faster depositing at high lift heights (optional).
- Control monitor for video camera (optional).

3-phase AC technology

Powerful 3-phase AC technology for simultaneous travel, lift and steering drive offers a range of advantages compared with traditional direct current motors.

- Powerful acceleration.
- Quick reversing without „moment of reflection“.
- High operational availability through maintenance-free motors without carbon brushes.
- Longer operating times through energy reclamation when speed is taken back and during lowering of load (optional).
- 2 years warranty on drive and lift motor.

Jungheinrich UK Ltd.

Head Office:

Sherbourne House · Sherbourne Drive
Tilbrook · Milton Keynes MK7 8HX
Phone 01908 363100
Fax 01908 363180

info@jungheinrich.co.uk
www.jungheinrich.co.uk

Jungheinrich AG
ISO 9001, ISO 14001
Certification of Quality and
Environment Management.



Jungheinrich trucks
conform to the European
Safety Requirements.



JUNGHEINRICH
Well worthwhile